		DENOMINAÇÃO		DESENHO N°
		Aglom 15mm	///	01/03
DESENHO	Edu	MATERIAL	ACABAMENTO	FOLHA N°
RESPONSÁVEL	Maichel		(+/- 0,10) TOL. ã. ESP.	CÓDIGO
ULTIMA ATUALIZAÇÃO	13/6/2011			ESCALA
APROVADO		USO: Automotivo (Toyota Hilux CD)		SUBST. POR DES N°
DATA	13/6/2011			

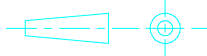

Seção A-A

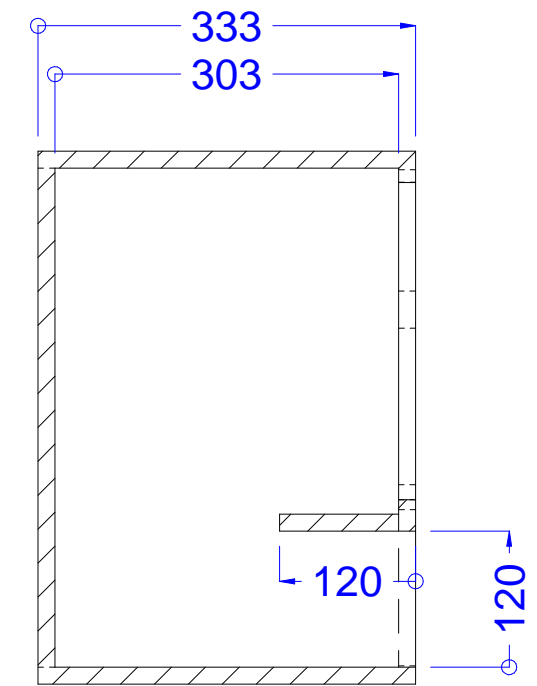

		Caixa 12 + Drivers + ST		DESENHO N°	
		DENOMINAÇÃO		02/03	
DESENHO	Edu	Aglom 15mm	///	FOLHA N°	
RESPONSÁVEL	Maichel	MATERIAL	ACABAMENTO	Código	
ULTIMA ATUALIZAÇÃO	13/6/2011			SUBSTITUE DES N°	
APROVADO				ESCALA	(+/- 0,10)
DATA	13/6/2011	PROJEÇÃO	ESCALA	TOL. n. ESP.	
		USO: Automotivo (Toyota Hilux CD)			

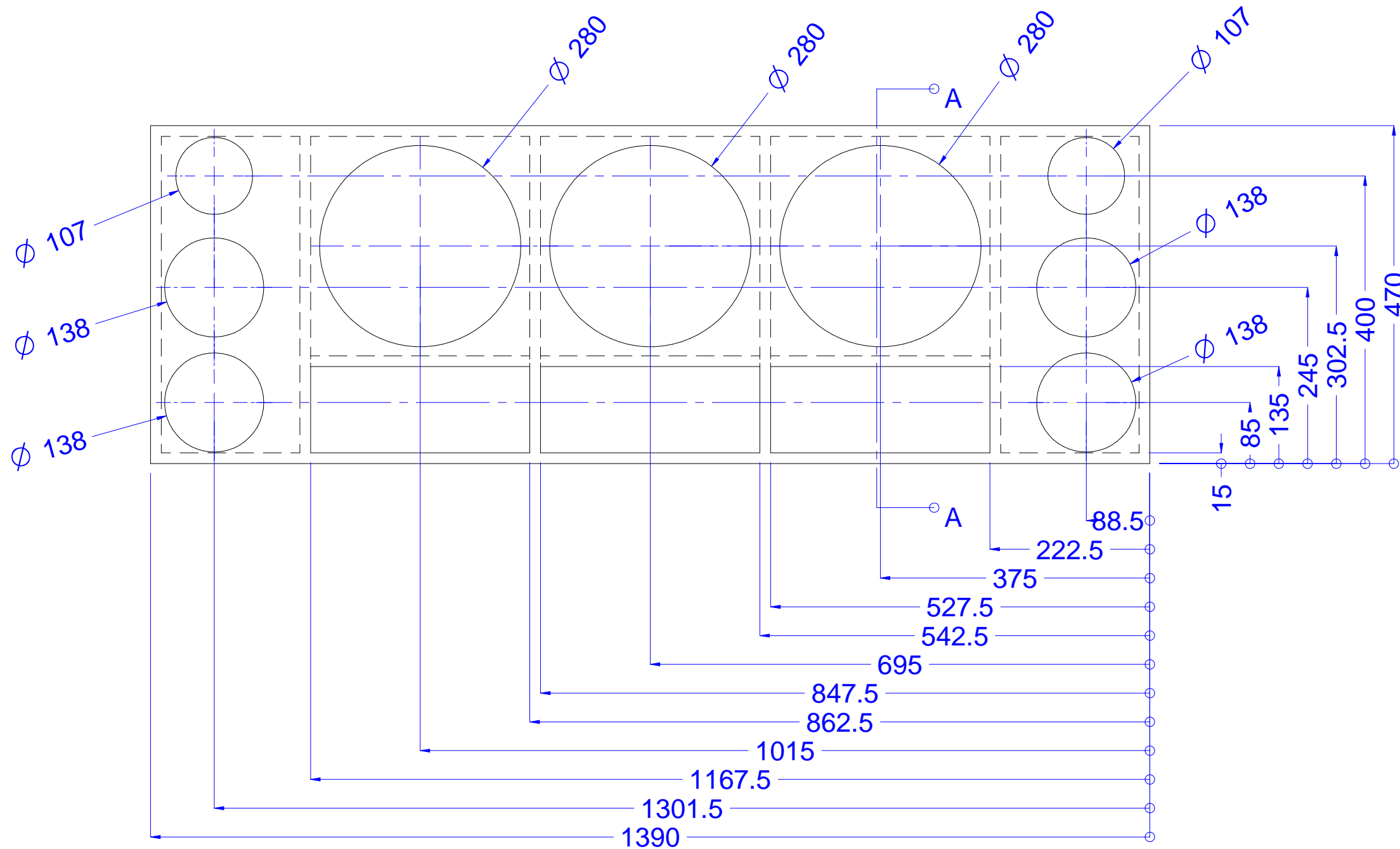
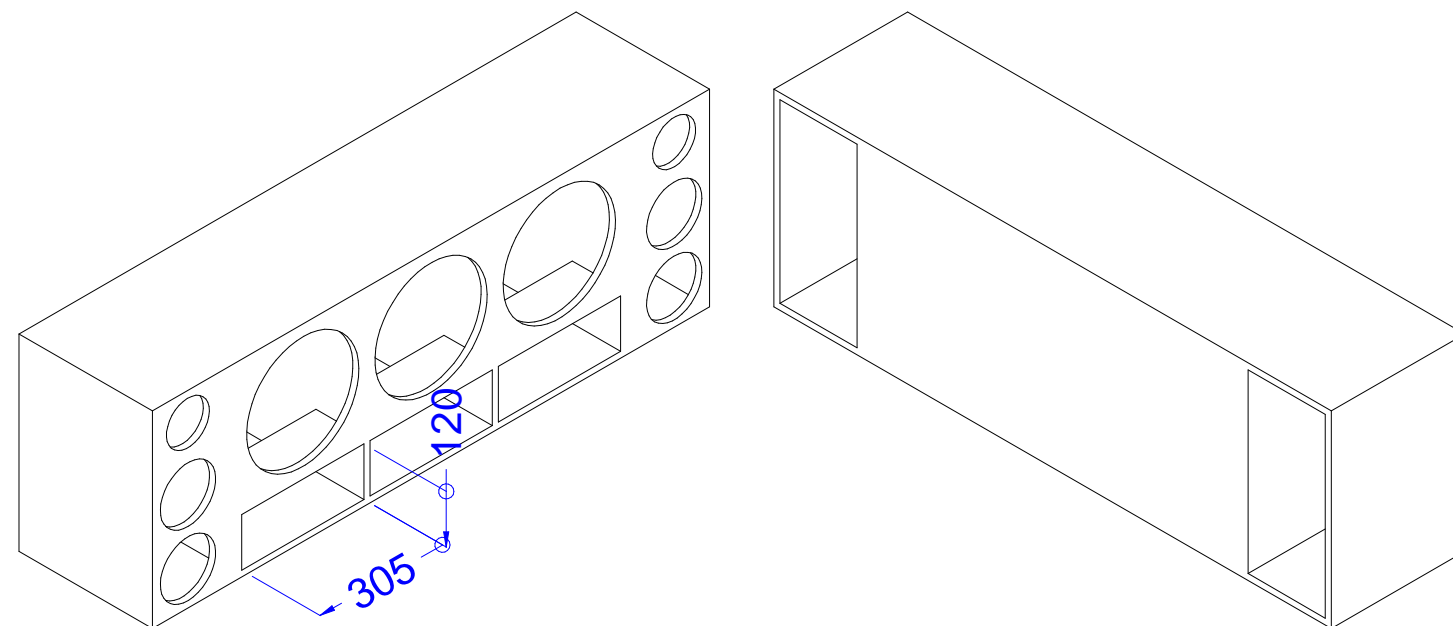
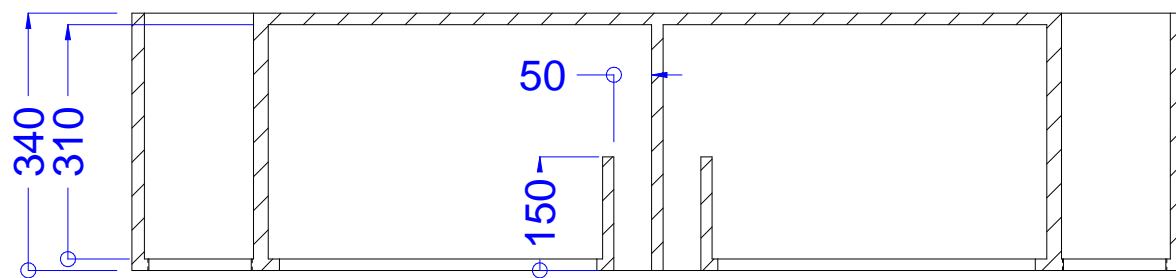
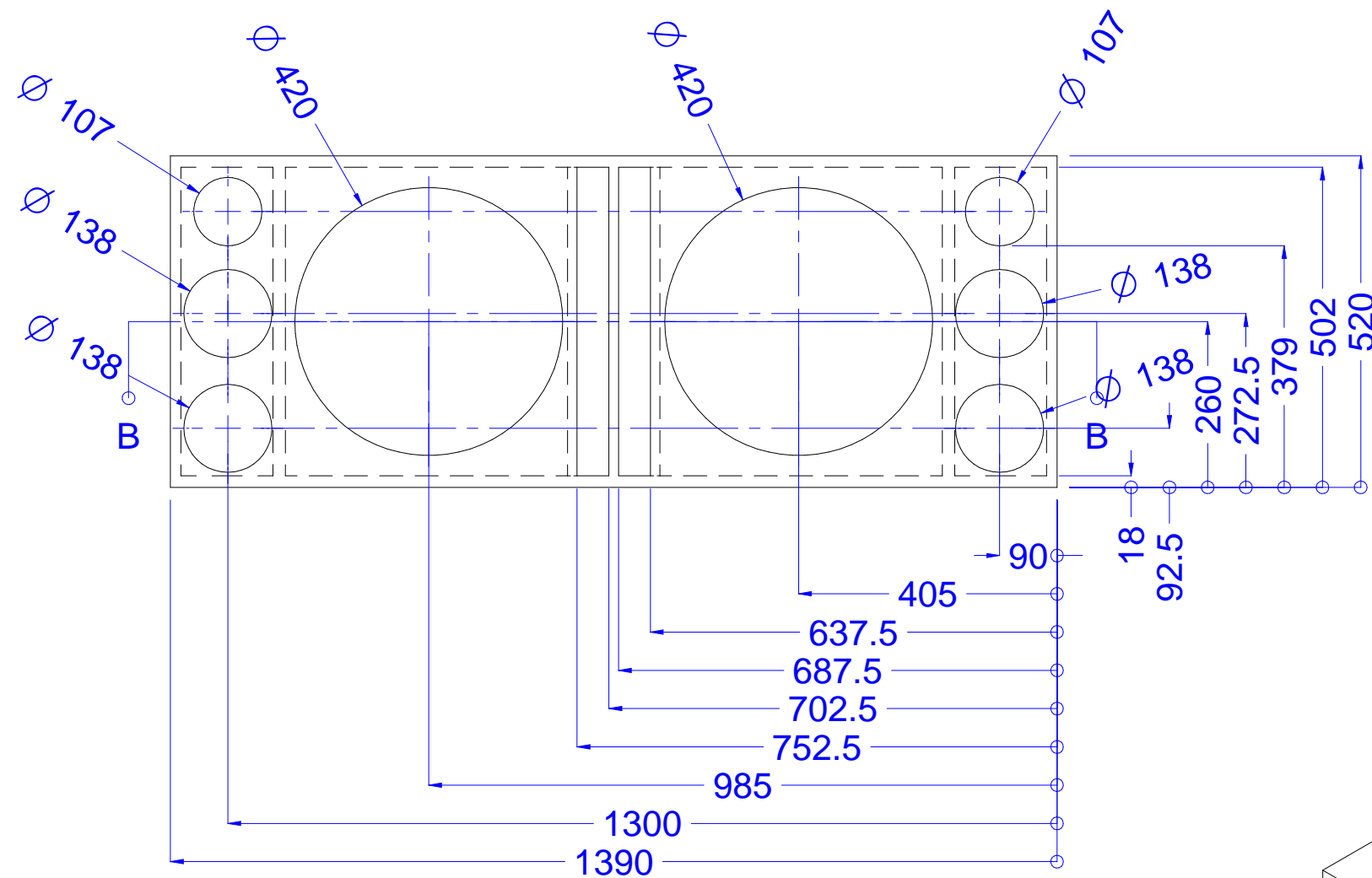

Seção B-B

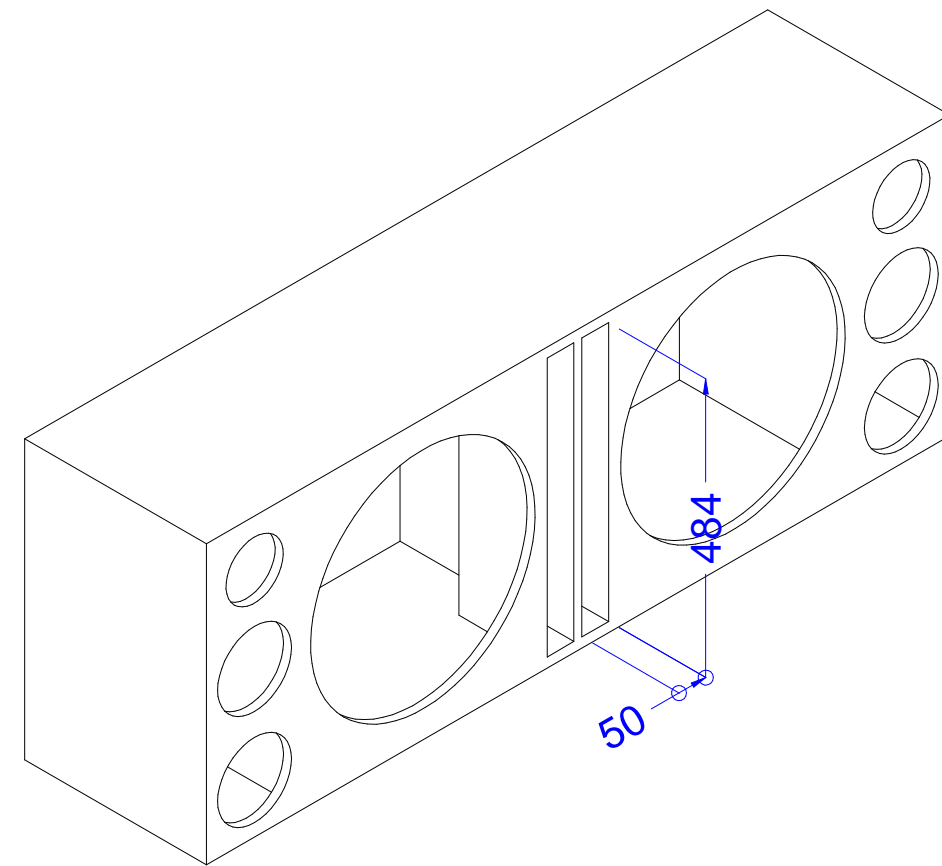

		Caixa 18 + Drivers + ST		DESENHO N°
		DENOMINAÇÃO		03/03
DESENHO	Edu	Aglom 15mm	///	FOLHA N°
RESPONSÁVEL	Maichel	MATERIAL	ACABAMENTO	CÓDIGO
ULTIMA ATUALIZAÇÃO	13/6/2011	PROJEÇÃO	ESCALA	TOL. n. ESP.
APROVADO				(+/- 0,10)
DATA	13/6/2011	USO: Automotivo (Toyota Hilux CD)		SUBSTITUE DES N°
				SUBST. POR DES N°