



|   |           |   |            |                   |
|---|-----------|---|------------|-------------------|
|  |           | Montagem do Conjunto  |            | DESENHO N°        |
|   |           | DENOMINAÇÃO   |            | 01/04             |
| DESENHO   | Edu       | MDF 15mm  |            | FOLHA N°          |
| RESPONSÁVEL   | Felipe    | MATERIAL  | ACABAMENTO | CÓDIGO            |
| ULTIMA ATUALIZAÇÃO  | 23/2/2011 |  | (+/- 0,10) |                   |
| APROVADO  |           |   | ESCALA     | TOL. n. ESP.      |
| DATA  | 18/2/2011 | USO: Automotivo   |            | SUBST. POR DES N° |



|                    |           |                     |            |                   |
|--------------------|-----------|---------------------|------------|-------------------|
|                    |           | Caixa 18 Nokaut 2K5 |            | DESENHO N°        |
| DESENHO            | Edu       | MDF 15mm            |            | 02/04             |
| RESPONSÁVEL        | Felipe    | MATERIAL            | ACABAMENTO | FOLHA N°          |
| ULTIMA ATUALIZAÇÃO | 23/2/2011 |                     | (+/- 0,10) | CÓDIGO            |
| APROVADO           |           | PROJEÇÃO            | ESCALA     | TOL. n. ESP.      |
| DATA               | 18/2/2011 | USO: Automotivo     |            | SUBSTITUE DES N°  |
|                    |           |                     |            | SUBST. POR DES N° |

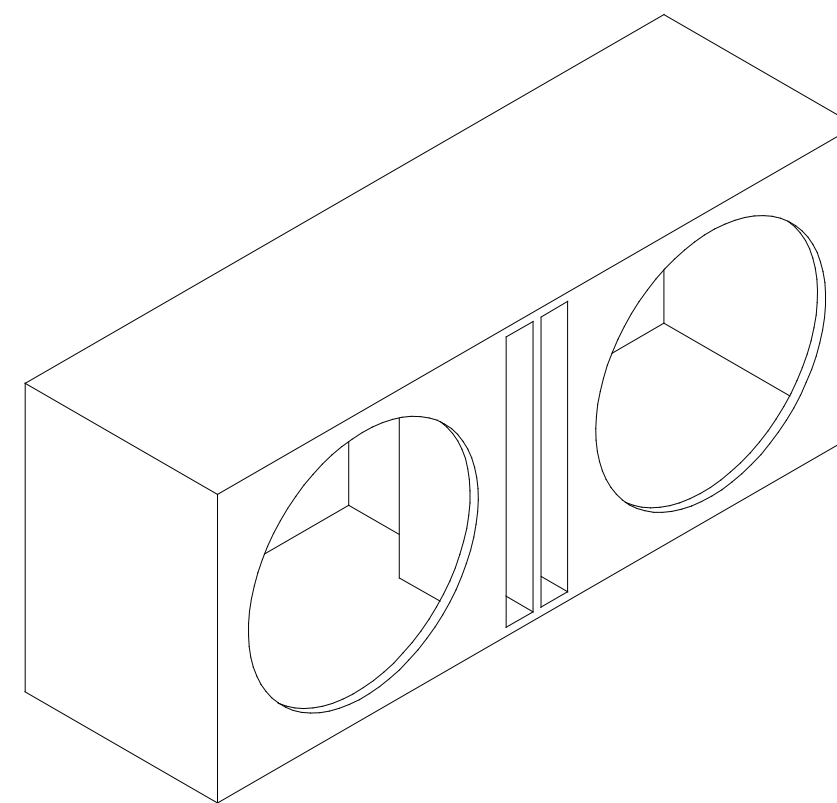
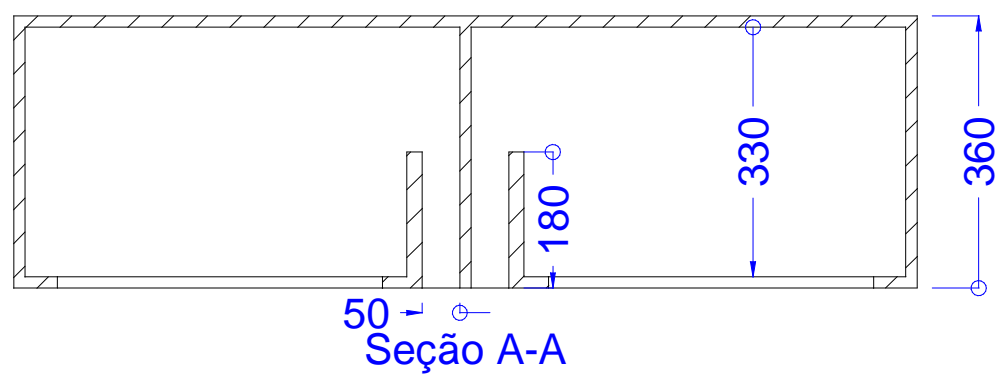
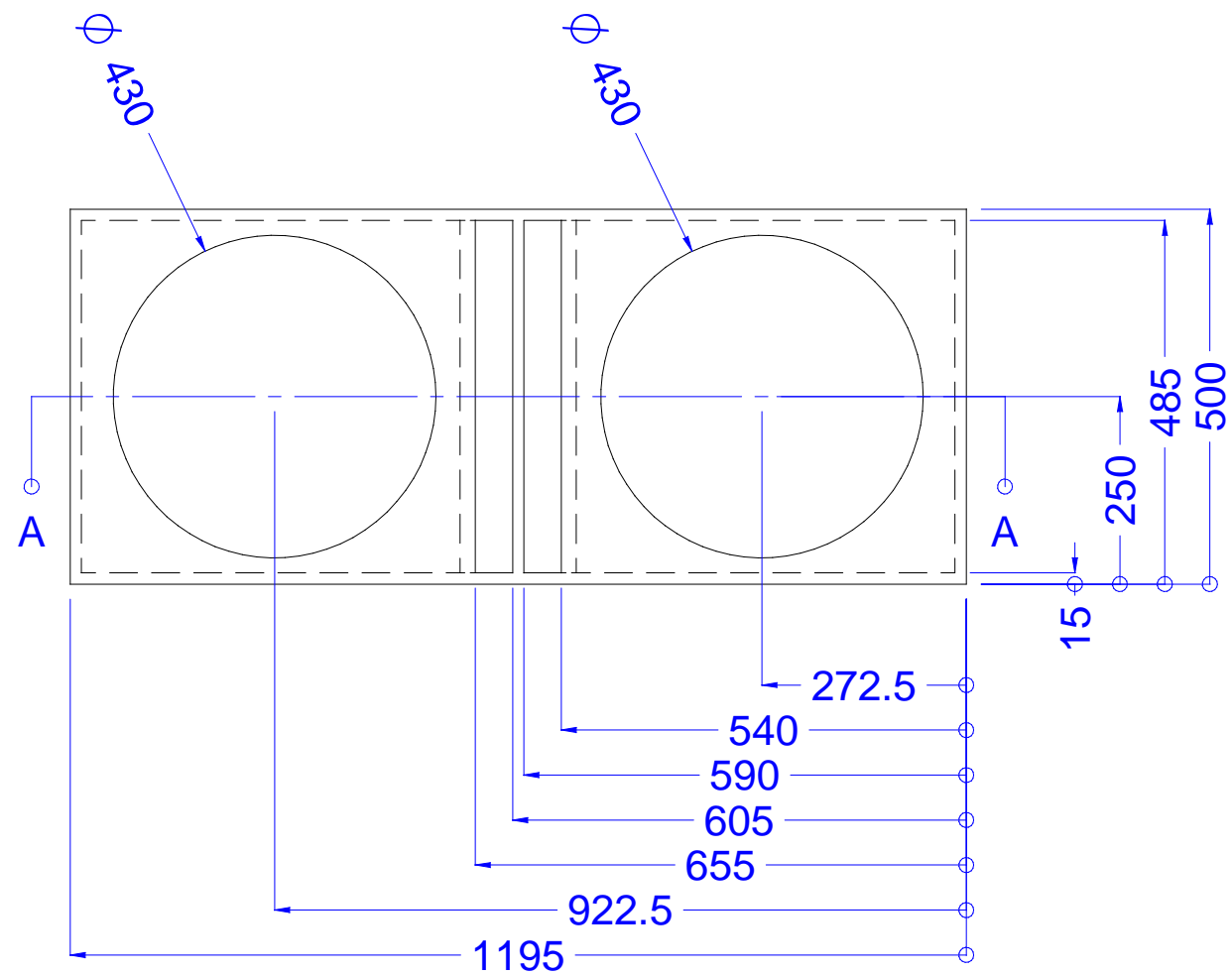
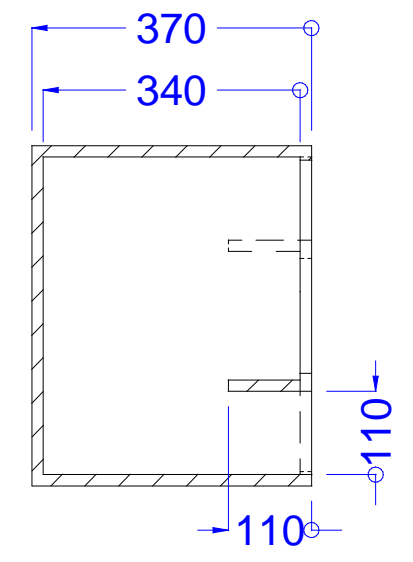
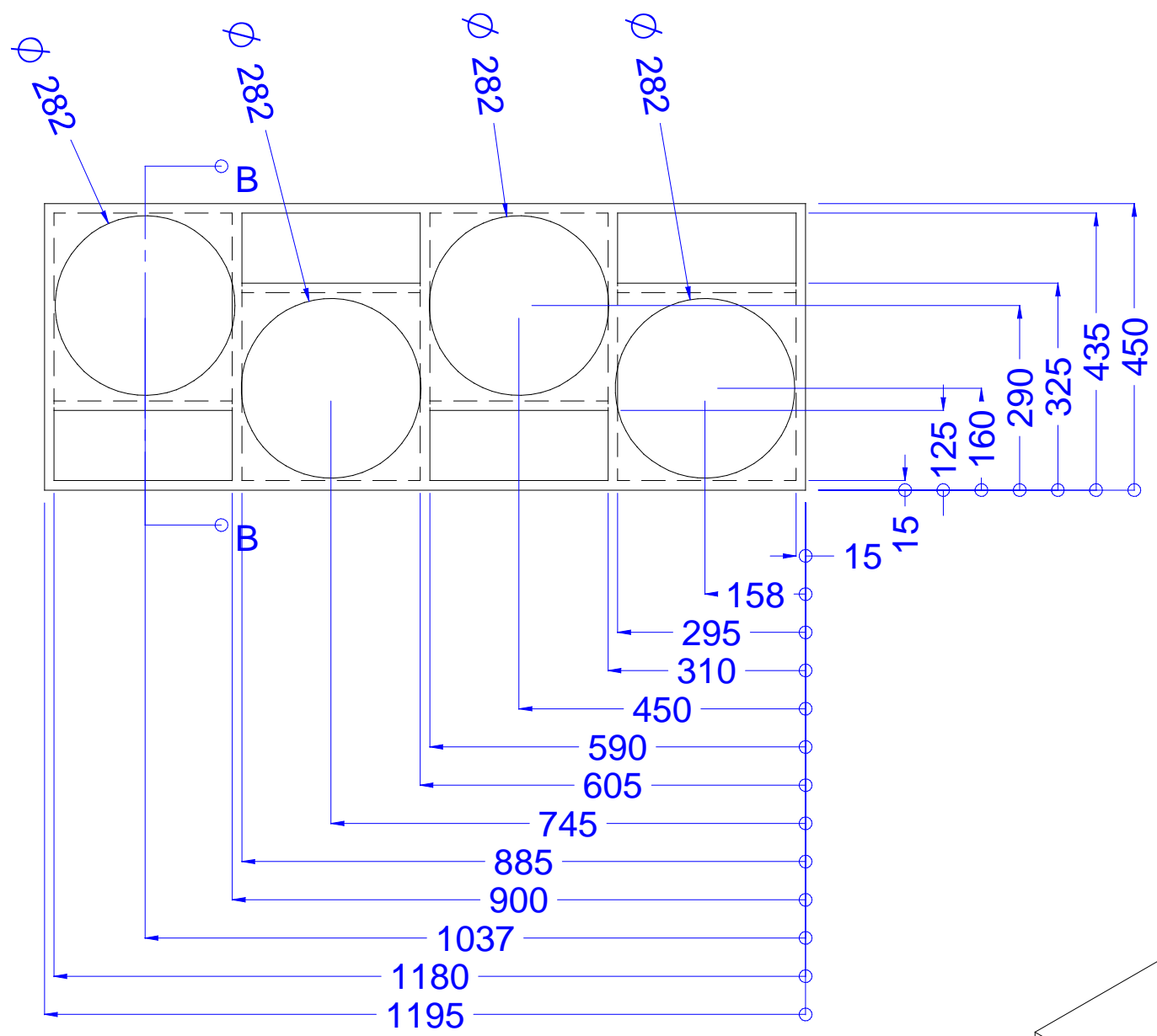

Seção B-B

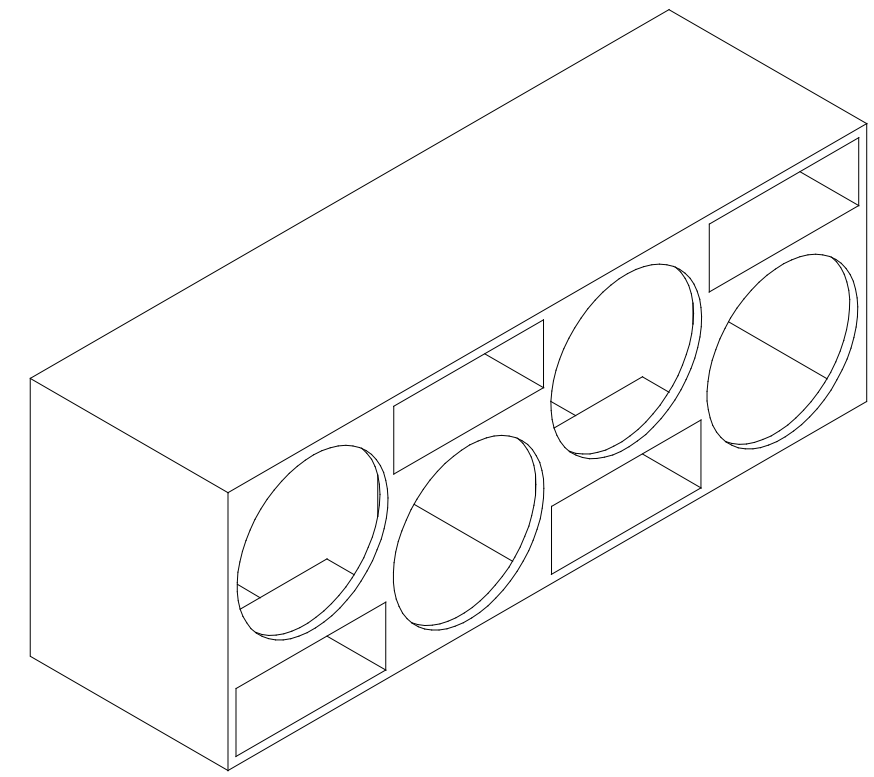

|                                |                      |                            |            |                   |
|--------------------------------|----------------------|----------------------------|------------|-------------------|
|                                |                      | Caixa 12 Batstaka MB 6K    |            | DESENHO N°        |
|                                |                      | DENOMINAÇÃO                |            | 03/04             |
| DESENHO   Edu                  | RESPONSÁVEL   Felipe | MDF 15mm                   | ACABAMENTO | FOLHA N°          |
| ULTIMA ATUALIZAÇÃO   23/2/2011 | APROVADO             | PROJEÇÃO                   | ESCALA     | CÓDIGO            |
| DATA   18/2/2011               | USO: Automotivo      | (+/- 0,10)<br>TOL. ã. ESP. |            | SUBSTITUE DES N°  |
|                                |                      |                            |            | SUBST. POR DES N° |

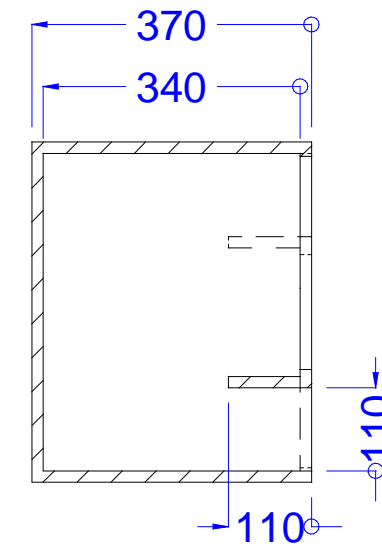
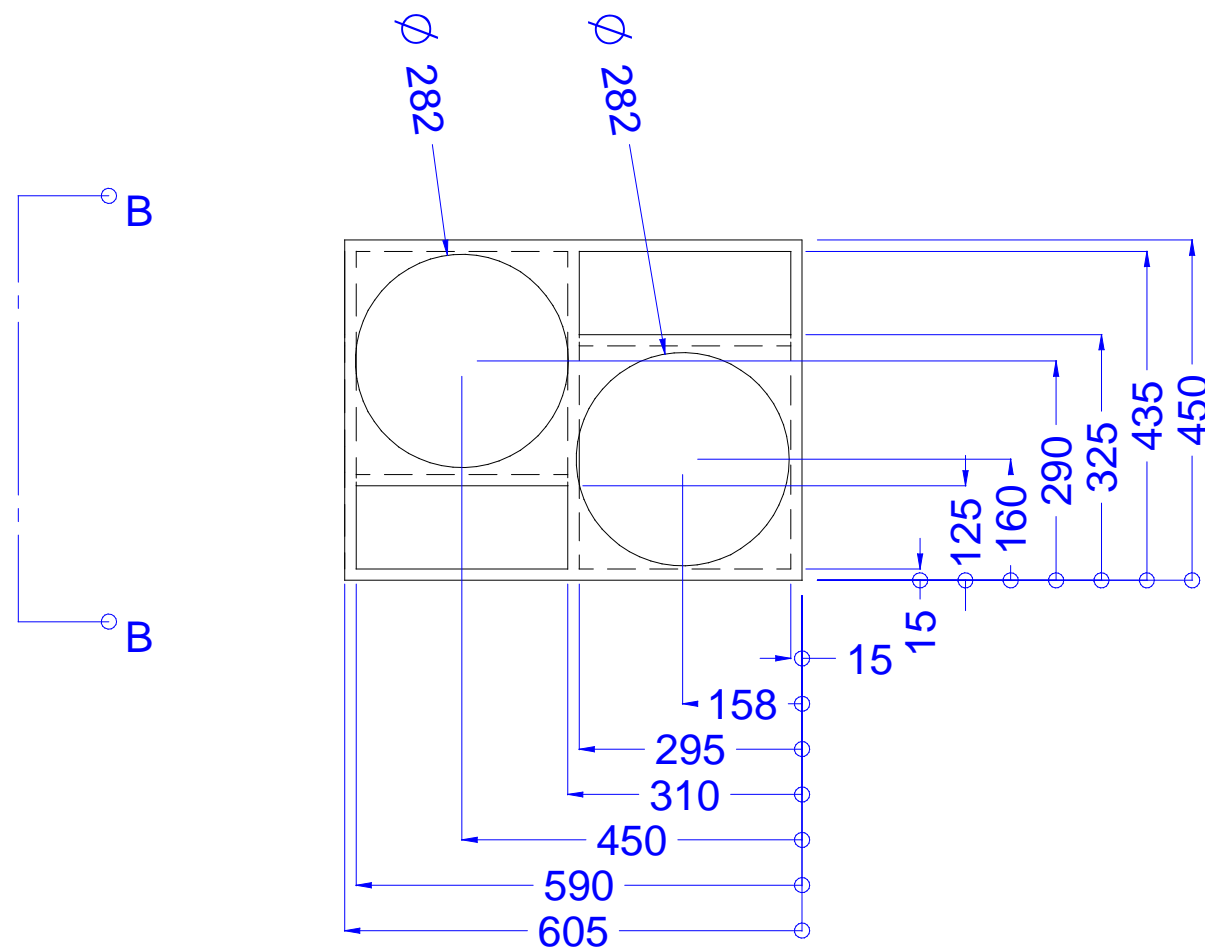

Seção B-B

|   |           |                                    |        |                   |
|---|-----------|------------------------------------|--------|-------------------|
|  |           | Caixa 12 Batstaka MB 6K - laterais |        | DESENHO N°        |
|   |           | MDF 15mm                           |        | 04/04             |
| DESENHO   | Edu       | ACABAMENTO                         |        | FOLHA N°          |
| RESPONSÁVEL   | Felipe    | (+/- 0,10)                         |        | CÓDIGO            |
| ULTIMA ATUALIZAÇÃO  | 23/2/2011 | PROJEÇÃO                           | ESCALA | TOL. n. ESP.      |
| APROVADO  |           | USO: Automotivo                    |        | SUBSTITUE DES N°  |
| DATA  | 18/2/2011 |                                    |        | SUBST. POR DES N° |