

		Montagem do Conjunto		DESENHO N°	
		MDF 15mm		01/04	
DESENHO	Edu	MATERIAL		FOLHA N°	
RESPONSÁVEL	Felipe	ACABAMENTO		Código	
ULTIMA ATUALIZAÇÃO	27/10/2010	(+/- 0,10)		SUBSTITUE DES N°	
APROVADO		TOL. n. ESP.		SUBST. POR DES N°	
DATA	27/10/2010	PROJEÇÃO		USO: Automotivo	
		ESCALA			

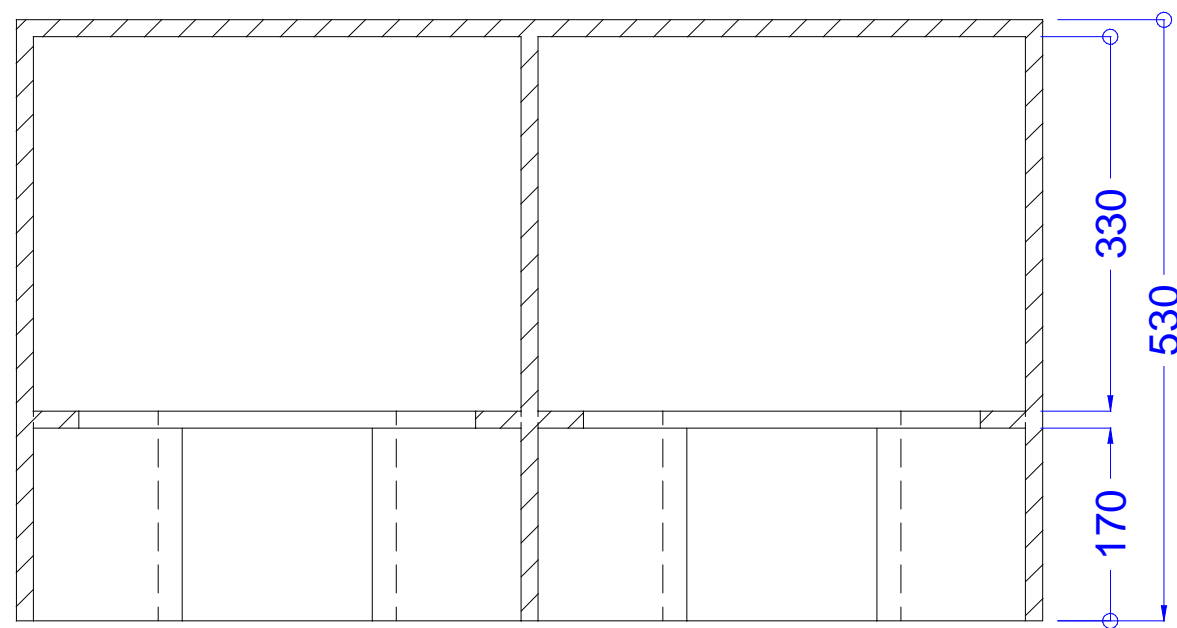

Seção A-A

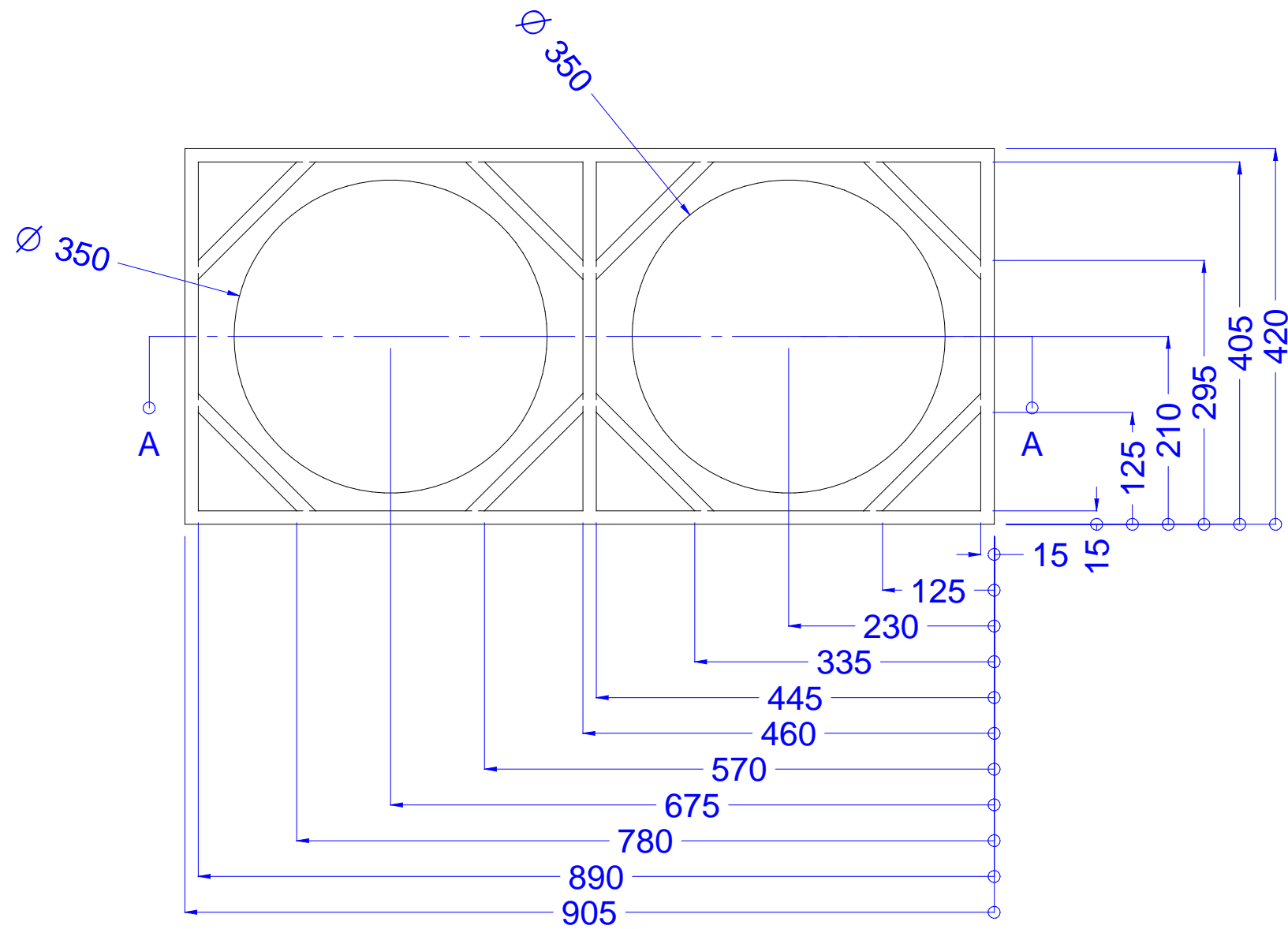
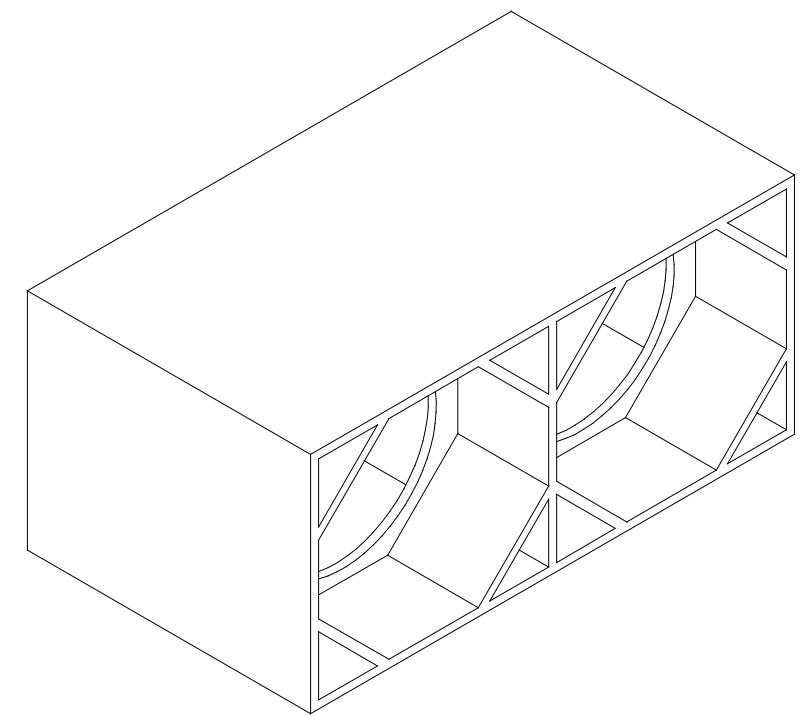

		Caixa 15 Batstaka 5K		DESENHO N°
		DENOMINAÇÃO		02/04
DESENHO	Edu	MDF 15mm	ACABAMENTO	FOLHA N°
RESPONSÁVEL	Felipe	MATERIAL	(+/- 0,10)	CÓDIGO
ULTIMA ATUALIZAÇÃO	27/10/2010	PROJEÇÃO	ESCALA	TOL. n. ESP.
APROVADO		USO: Automotivo		SUBSTITUE DES N°
DATA	27/10/2010			SUBST. POR DES N°

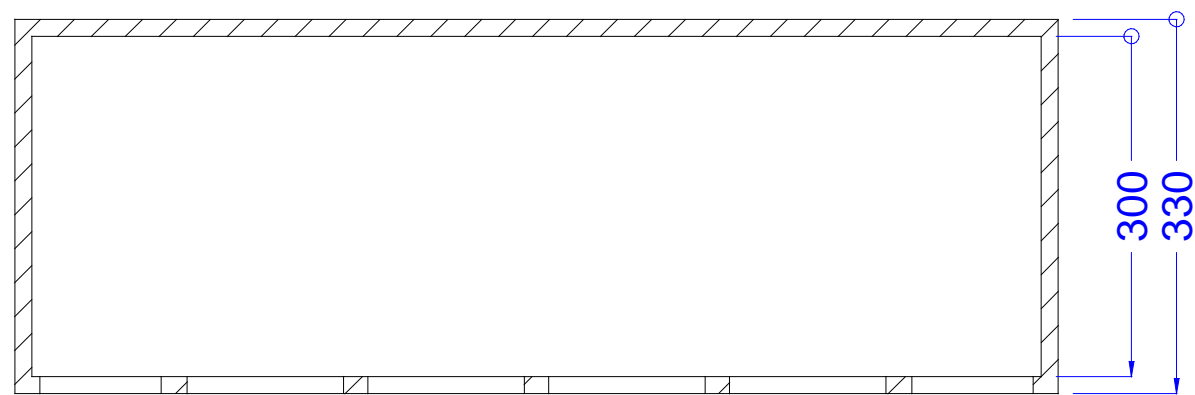
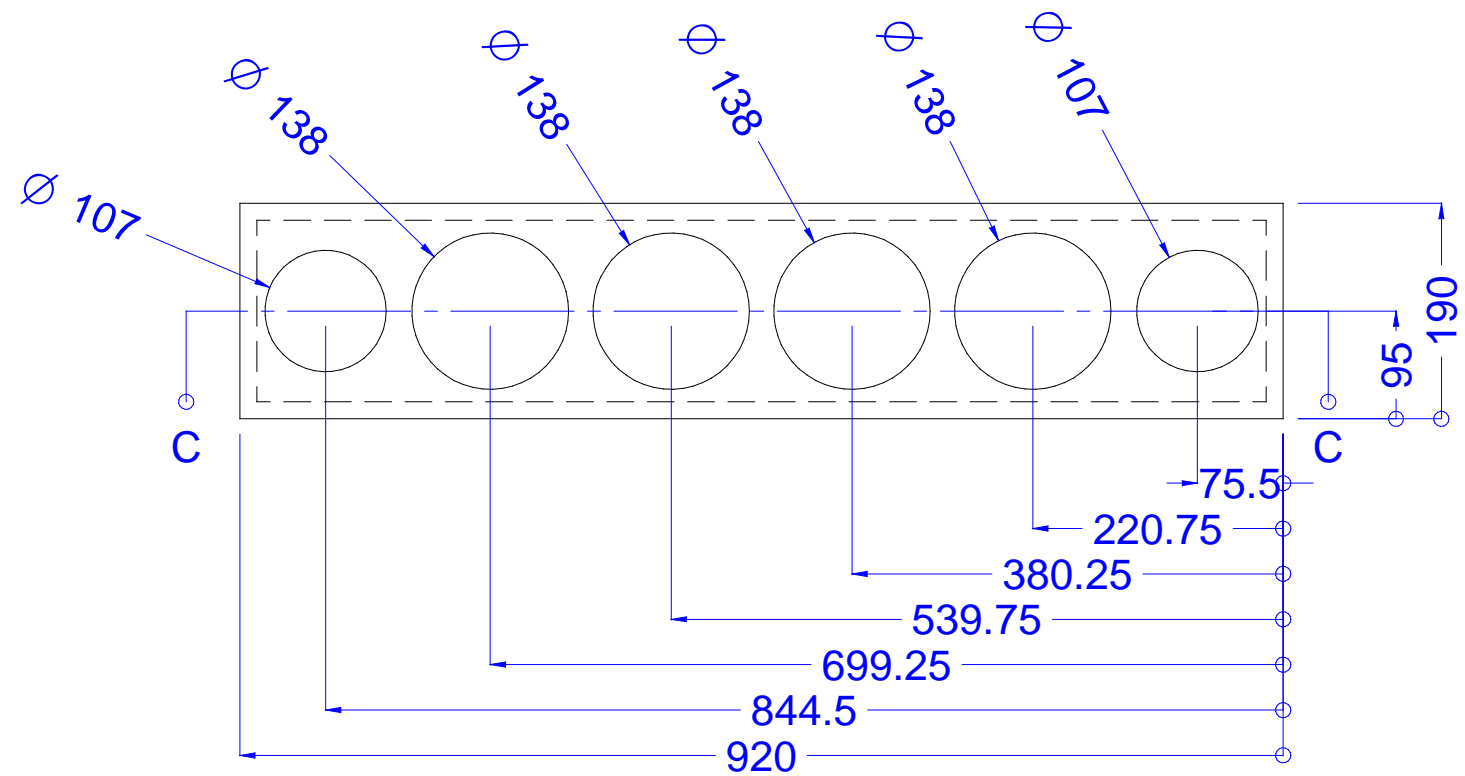

Seção C-C

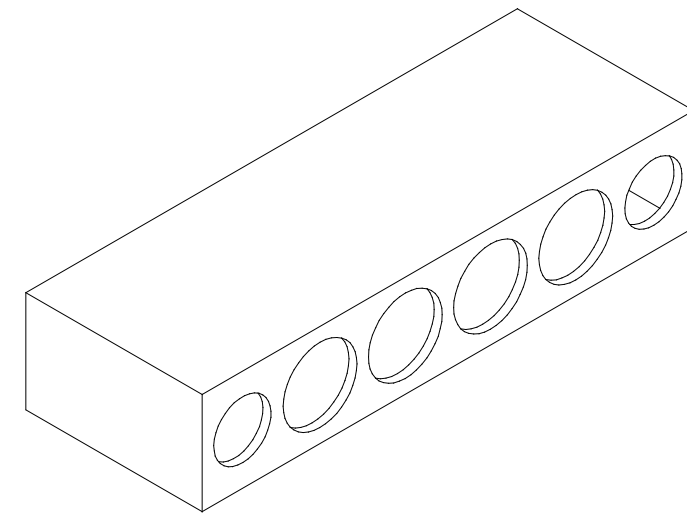

		Caixa Drivers e STs		DESENHO N°
		DENOMINAÇÃO		04/04
DESENHO Edu	RESPONSÁVEL Felipe	MDF 15mm	ACABAMENTO	FOLHA N°
ULTIMA ATUALIZAÇÃO 27/10/2010	APROVADO	MATERIAL	(+/- 0,10)	CÓDIGO
DATA 27/10/2010	USO: Automotivo	PROJEÇÃO	ESCALA	TOL. n. ESP.
				SUBSTITUE DES N°
				SUBST. POR DES N°